

**colt**

**Colt Partner Internet Access  
- Wireless Internet Services -**



# Challenges in existing Wireless Internet services – SDWAN Underlay Use Case -

## Demands for Wireless Connectivity

- Locations where optical cable wiring is difficult
- Wireless Backup
- Short-term use



## Challenges in Existing Wireless Internet services

- Best Effort
- Service outage when incidents in MNO
- Difficult to predict charge in usage billing
- Speed is throttled if bundled data consumed
- No 24x7 monitoring & Service Desk
- No faulty CPE replacement
- No SLA

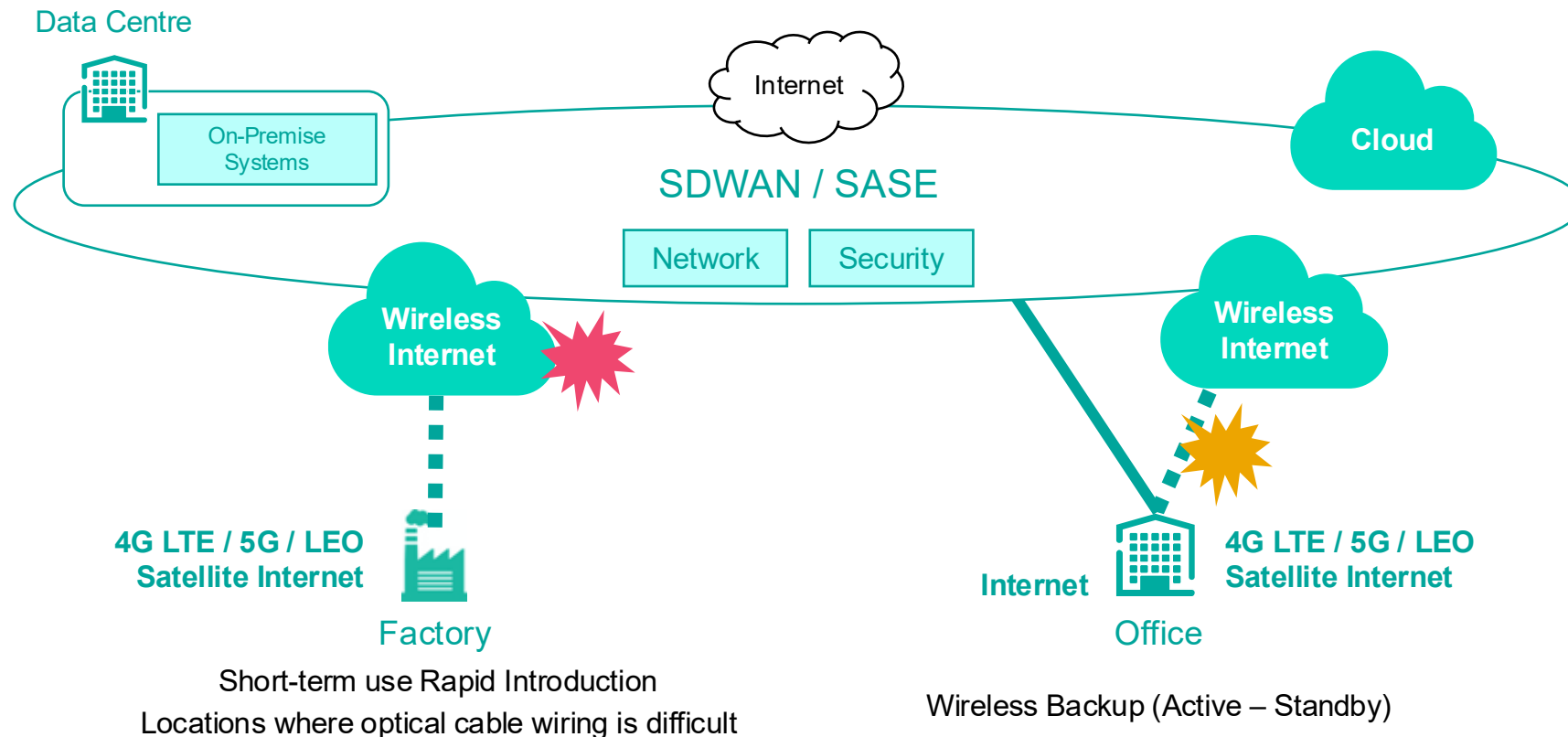

# Benefits of Colt Wireless Internet Services

## Demands for Wireless Connectivity

- Locations where optical cable wiring is difficult
- Wireless Backup
- Short-term use



## Colt Wireless Internet Services

- Bandwidth Guarantee (50% of Contracted Bandwidth)
- Multiple MNO Redundancy
- Flat Pricing
- Data Unlimited or Data Limited
- 24x7 monitoring & Service Desk
- Faulty CPE replacement
- SLA
- Covering approx 90 countries

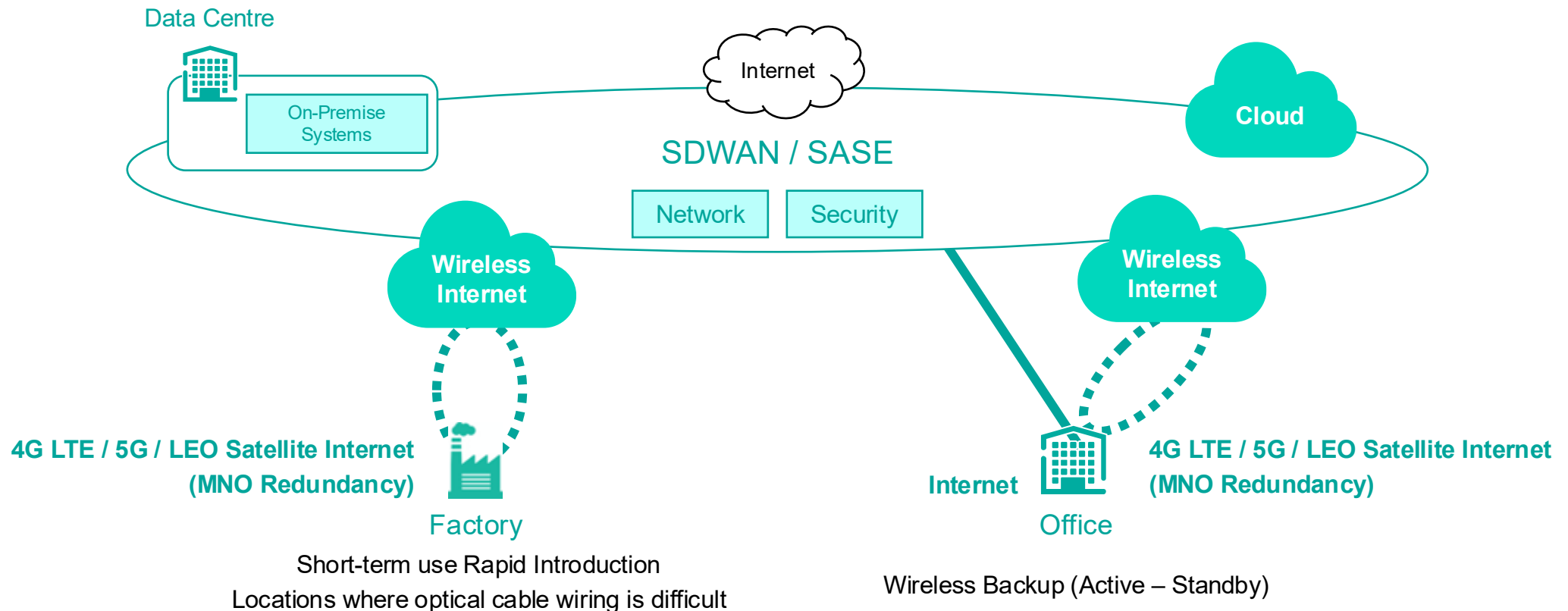

# Challenges in existing Wireless Internet services – Use Case for Cloud Access via Internet -

## Demands for Wireless Connectivity

- Locations where optical cable wiring is difficult
- Wireless Backup
- Short-term use



## Challenges in Existing Wireless Internet services

- Best Effort
- Service outage when incidents in MNO
- Difficult to predict charge in usage billing
- Speed is throttled if bundled data consumed
- No 24x7 monitoring & Service Desk
- No faulty CPE replacement
- No SLA

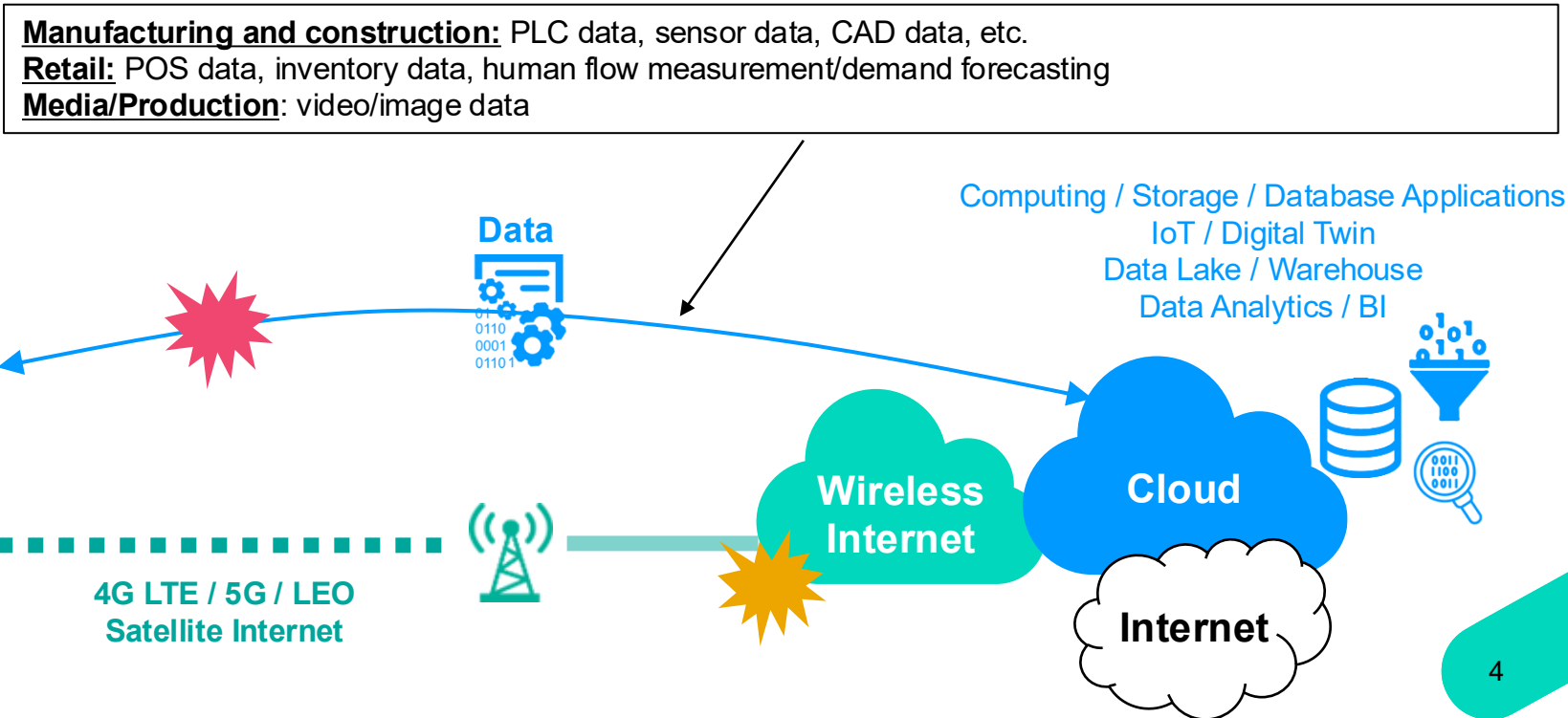
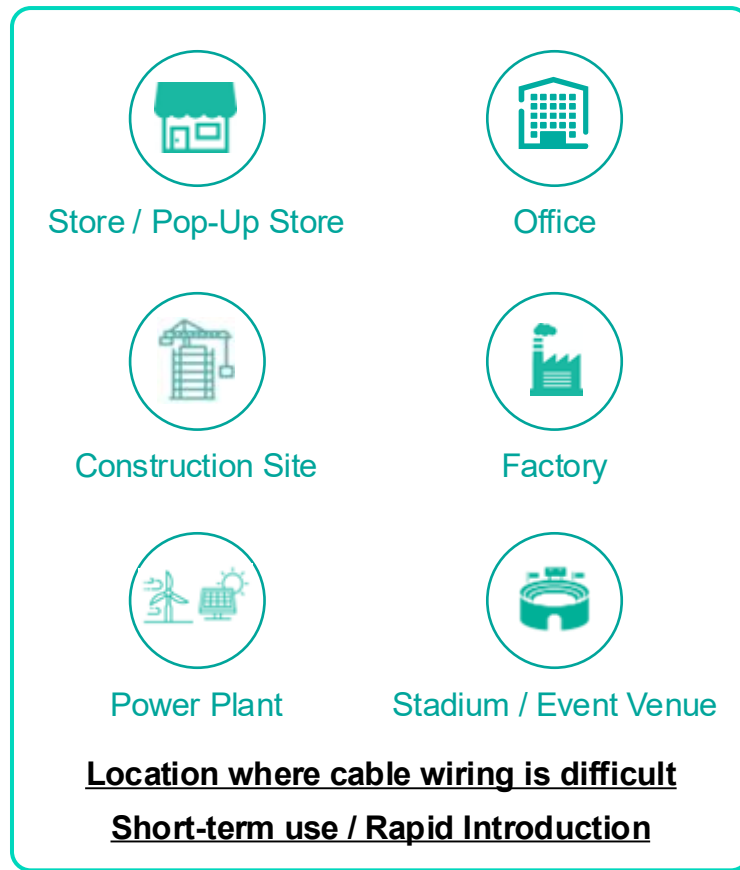

# Benefits of Colt Wireless Internet Services

## Demands for Mobile Connectivity

- Locations where optical cable wiring is difficult
- Wireless Backup
- Short-term use

## Colt Wireless Internet Services

- Bandwidth Guarantee (50% of Contracted Bandwidth)
- Multiple MNO Redundancy
- Flat Pricing
- Data Unlimited or Data Limited
- 24x7 monitoring & Service Desk
- Faulty CPE replacement
- SLA
- Covering approx 90 countries

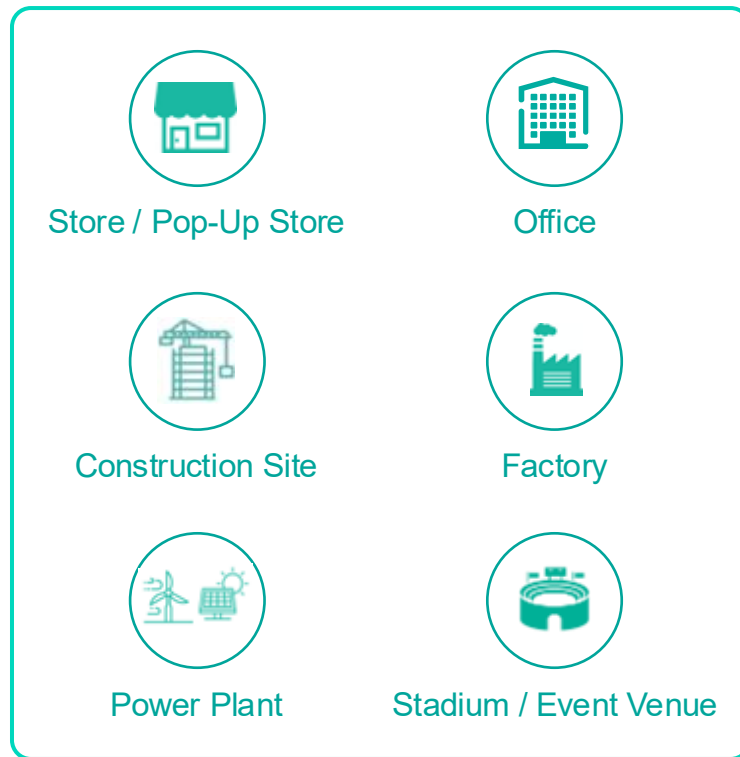

**Manufacturing and construction:** PLC data, sensor data, CAD data, etc.  
**Retail:** POS data, inventory data, human flow measurement/demand forecasting  
**Media/Production:** video/image data

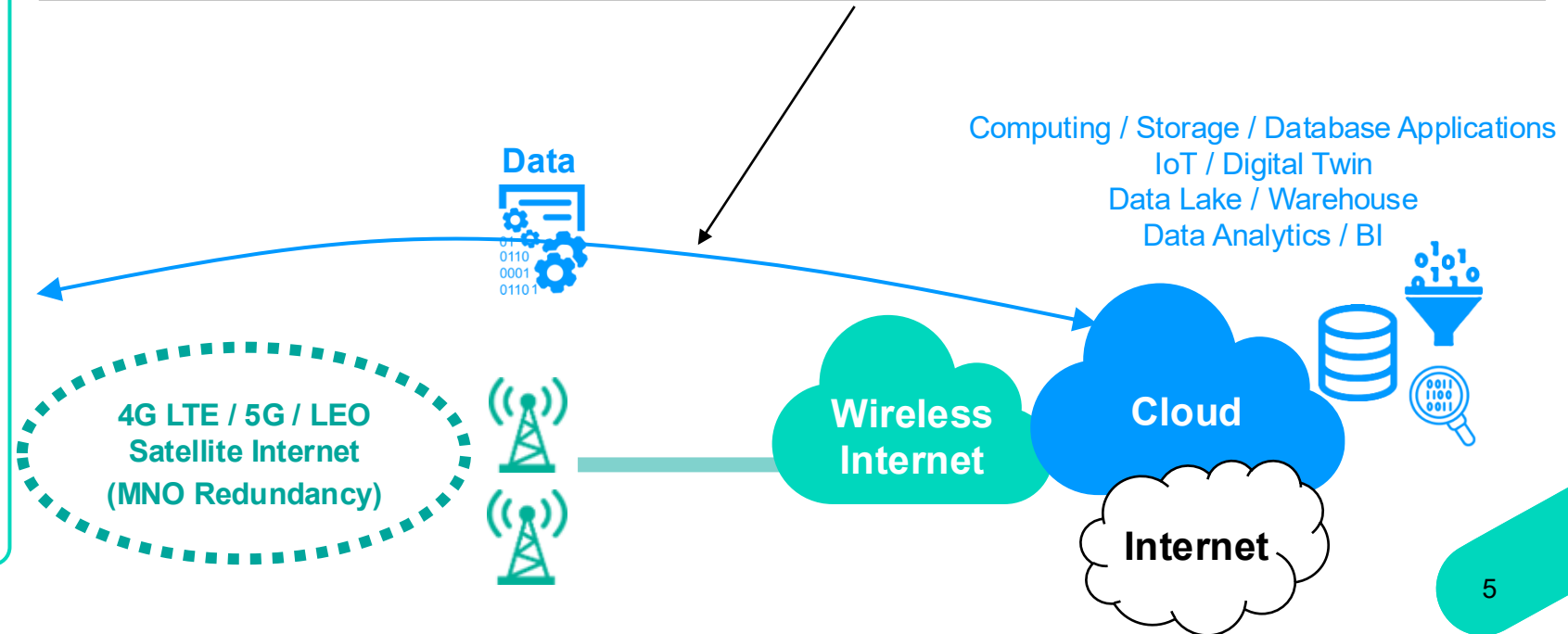

# Partner Internet Access – Wireless Internet Services -

## Global Wireless Access

- 4G LTE / 5G Wireless Access
- Bandwidth Options: 2Mbps - 100Mbps
- 50% bandwidth guaranteed
- Unlimited Plan or Limited Plan with no extra charge
- Dual SIM for MNO/MVNO redundancy
- Service Coverage: Approx 90 countries
- Installation
- 24 x 7 managed service & On-site Support

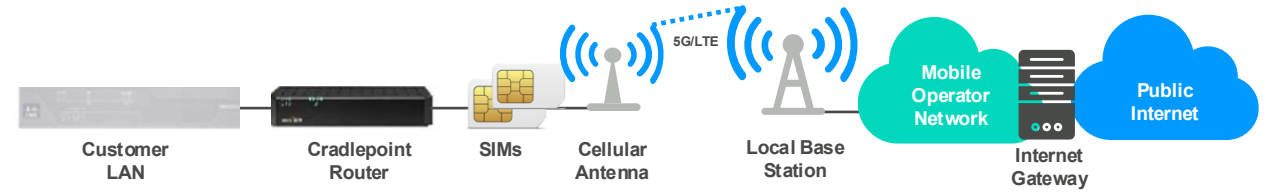

## Global Managed LEO

- Starlink LEO (Low Earth Orbit)
- Service bandwidth 50Mbps/ 10Mbps
- 50% bandwidth guaranteed (25Mbps/5Mbps)
- 1TB/2TB Limited Priority Data, thereafter Unlimited, throttled Low Priority Data
- Priority data is upgradable in 1TB increments
- Service Coverage: 57 countries
- Site Survey & Installation
- 24 x 7 managed service & On-site Support

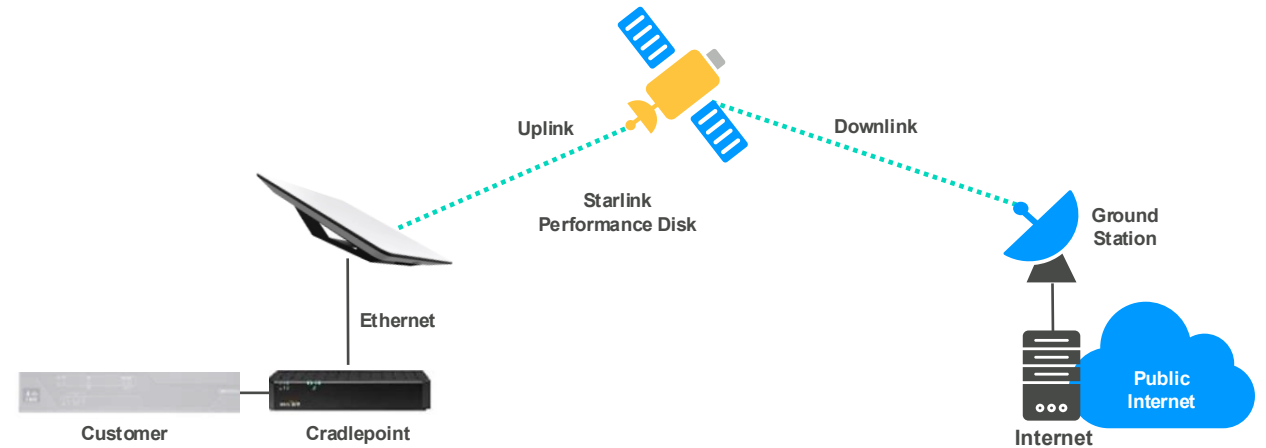

## Global Managed LEO Plus

- Starlink LEO (Low Earth Orbit) + 4G/5G Wireless Access
- Service bandwidth 50Mbps/ 10Mbps
- 50% bandwidth guaranteed (25Mbps/5Mbps)
- 1TB/2TB Limited Priority Data, thereafter Unlimited, throttled Low Priority Data
- Priority data is upgradable in 1TB increments
- Service Coverage: 57 countries
- Site Survey & Installation
- 24 x 7 managed service & On-site Support

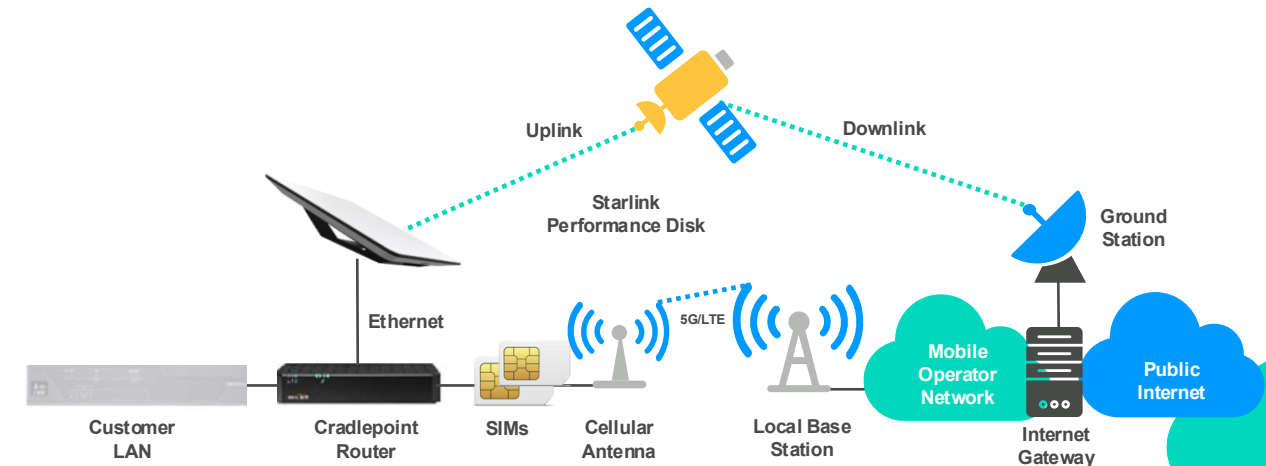

# Wireless Internet Services – Global Wireless Access –

## Equipment

Cradlepoint Antennas | WiFi



## 5G/LTE Data

SIM Cards | Pool Data



## Field Services

Delivery | Installation | Support



## Management

Configuration | Helpdesk | SLA

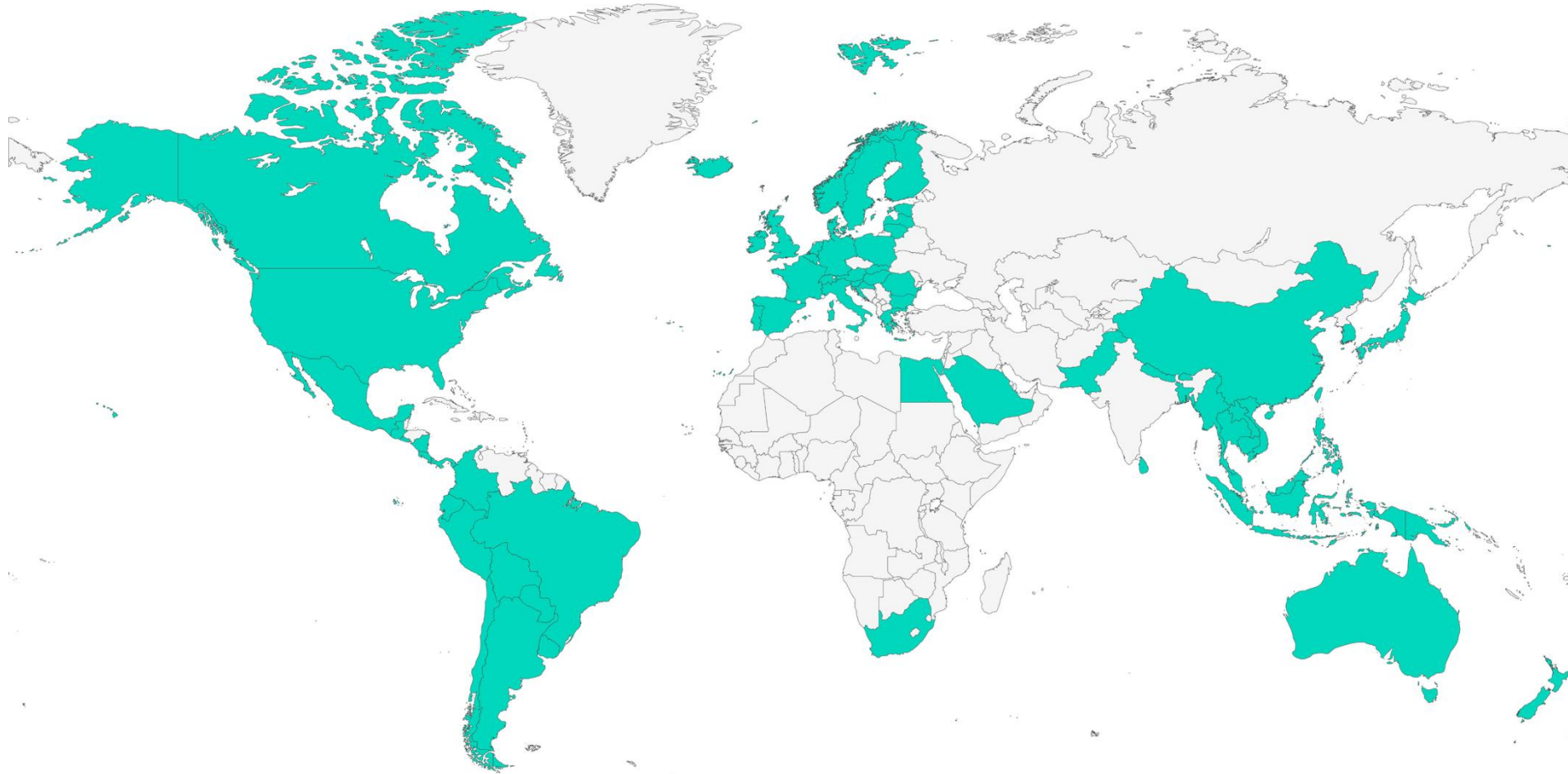

# Wireless Internet Services – Global Managed LEO / Global Managed LEO Plus –

## Equipment

Cradlepoint Antennas | WIFI



## 5G/LTE Data

SIM Cards | Pool Data



## Field Services

Delivery | Installation | Support



## Management

Configuration | Helpdesk | SLA

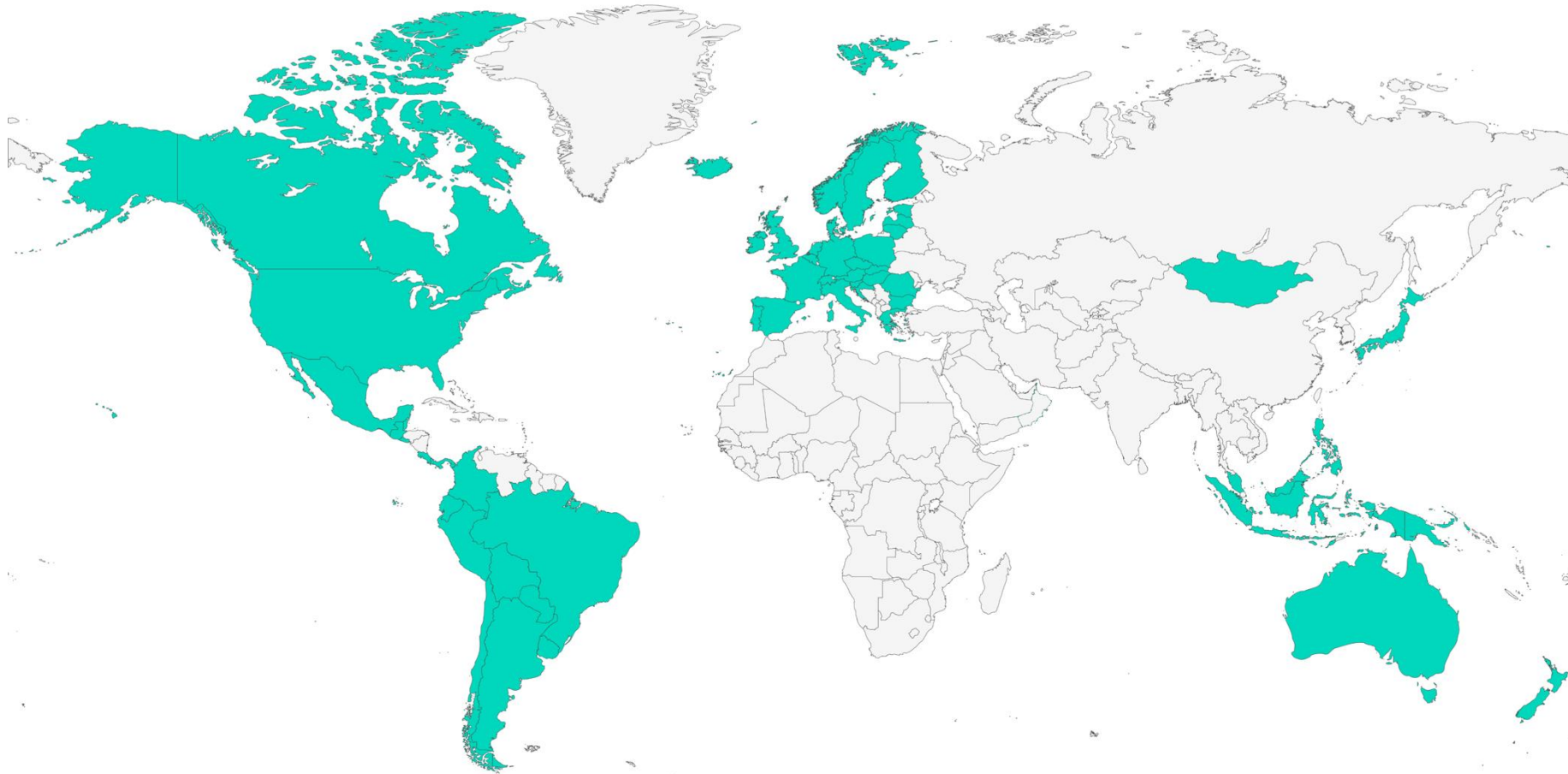

## Partner Internet Access – Wireless Internet Services - Service Specifications -

Category	Global Wireless Access	Global Managed LEO	Global Managed LEO Plus
Wireless Technology	4G LTE / 5G	LEO Satellite only	LEO satellite and 4G LTE / 5G
Data Plans	Unlimited Data (Primary Plan) Limited Data (Infinity Plans)	1TB/2TB Limited Priority Data, thereafter Unlimited Low Priority Data (Upgradable up to 6TB)	
Service Bandwidths [Mbps]	2/2, 5/2, 5/5, 10/5, 10/10, 20/10, 40/10, 50/20, 100/20 (Downstream / Upstream)	50/10 (Downstream / Upstream)	50/10 (Downstream / Upstream)
Bandwidth Guaranteed	Guaranteed 50% of of Service Bandwidth		
Multi SIM for Redundancy	2 x SIM cards are inserted into mobile router as default except specific countries.	N/A	2 x SIM cards are inserted into mobile router as default except specific countries.
LAN Interface	1000BASE-T (Default)		
LAN IP address	Private IP Address (Default)		
Delivery Lead-Time	20 Business days	40 Business days	
Minimum Contract	3 / 12 / 24 / 36 months		
Monitoring	24x7		
SLA	Availability, TTTR, Delivery Lead-Time, Bandwidth Guaranteed of Access circuit		
Add-ons	Upgrade Priority Data in 1TB increments		
	Public Static IPv4 (/29, /30, /31)		
	Wi-Fi Interface		
	Multiple LAN Interfaces		

# Partner Internet Access – Service Level Agreement (SLA) -

## Availability

If service availability falls below target, the customer has the right to claim service credit for the affected service. (\* CPE Router in Wireless Access is not covered by the SLA.)

SLA Tier	Target Availability (%)
Off-net Tier 1	99.85
Off-net Tier 2	99.80
Off-net Tier 3	98.50
Off-net Tier 4	98.00

% points below target Service Availability	Service credits (% of monthly service charges)	
	Off-net Tier 1	Off-net Tier 2/3/4
> 0 & ≤ 0.5	5	5
> 0.5 & ≤ 1.0	10	
> 1.0 & ≤ 1.5	15	
More than 1.5	20	

## Target Time To Repair (TTTR)

TTTR is defined as the time from the time we issue a trouble ticket to the time the fault is resolved, either because the customer reports a fault or we detect a fault. If the TTTR is not met for any outage affecting service, the customer is entitled to claim a service credit for each individual service. (\* CPE Router in Wireless Access is not covered by the SLA.)

SLA Tier	TTTR for Service-Affecting Faults (hours)
Off-net Tier 1	8
Off-net Tier 2	12
Off-net Tier 3	24
Off-net Tier 4	48

Hours past TTTR)	Service credits (% of monthly service charges)	
	Off-net Tier 1	Off-net Tier 2/3/4
> 0 & ≤ 3	5	5
> 3 & ≤ 4	10	
> 4 & ≤ 6	15	
> 6	25	

## Bandwidth Guarantee (Access Speed Guarantee)

Bandwidth Guarantee (Access Speed Guarantee)

If a throughput degradation is suspected, throughput is measured remotely up on customer declaration.

If the measurement result is less than 50% of the contracted bandwidth, it will be treated as a failure and subject to availability and TTTR defined in the SLA. (\* Remote throughput measurement causes service interruption.)

## Partner Internet Access – Global Wireless Access – SLA Tiers -

Region	Country	Unlimited Data	Limited Data
Africa	South Africa	Tier4	Tier4
Americas	Argentina	Tier4	Tier4
	Bolivia	N/A	Tier4
	Brazil	Tier4	Tier4
	Canada	Tier1	Tier4
	Chile	N/A	Tier4
	Colombia	Tier4	Tier4
	Costa Rica	Tier4	Tier4
	Ecuador	Tier4	Tier4
	El Salvador	N/A	Tier4
	Guatemala	Tier4	Tier4
	Mexico	Tier4	Tier4
	Nicaragua	Tier4	Tier4
	Panama	Tier4	Tier4
	Paraguay	N/A	Tier4
	Peru	Tier4	Tier4
	Puerto Rico	Tier4	Tier4
	Uruguay	N/A	Tier4
	USA	Tier1	Tier4
	Asia Pacific	Australia	Tier1
Bangladesh		Tier4	Tier4
Bhutan		N/A	Tier4
Brunei		Tier4	Tier4
Cambodia		Tier4	Tier4
China		Tier3	Tier4
Guam		N/A	Tier4
Hong Kong		Tier1	Tier4
Indonesia		Tier3	Tier4
Japan		Tier1	Tier4
Laos		Tier4	Tier4

Region	Country	Unlimited Data	Limited Data	
Asia Pacific	Macau	Tier3	Tier4	
	Malaysia	Tier3	Tier4	
	Mongolia	Tier4	Tier4	
	Myanmar	Tier3	Tier4	
	Nepal	N/A	Tier4	
	New Zealand	Tier3	Tier4	
	Pakistan	N/A	Tier4	
	Papua New Guinea	N/A	Tier4	
	Philippines	Tier4	Tier4	
	Saipan	N/A	Tier4	
	Singapore	Tier1	Tier4	
	South Korea	Tier1	Tier4	
	Sri Lanka	Tier4	Tier4	
	Taiwan	Tier1	Tier4	
	Thailand	Tier3	Tier4	
	Vanuatu	N/A	Tier4	
	Vietnam	Tier3	Tier4	
	Europe	Austria	Tier4	Tier4
		Belgium	Tier4	Tier4
Bulgaria		Tier4	Tier4	
Croatia		Tier4	Tier4	
Cyprus		Tier4	Tier4	
Czech Republic		Tier4	Tier4	
Denmark		Tier4	Tier4	
Estonia		Tier4	Tier4	
Finland		Tier4	Tier4	
France		Tier4	Tier4	
Germany		Tier4	Tier4	
Gibraltar		Tier4	Tier4	

Region	Country	Unlimited Data	Limited Data
Europe	Greece	Tier4	Tier4
	Hungary	Tier4	Tier4
	Iceland	Tier4	Tier4
	Ireland	Tier4	Tier4
	Italy	Tier4	Tier4
	Latvia	Tier4	Tier4
	Liechtenstein	Tier4	Tier4
	Lithuania	Tier4	Tier4
	Luxembourg	Tier4	Tier4
	Malta	Tier4	Tier4
	Monaco	Tier4	Tier4
	Netherlands	Tier4	Tier4
	Norway	Tier4	Tier4
	Poland	Tier4	Tier4
	Portugal	Tier4	Tier4
	Romania	Tier4	Tier4
	Slovakia	Tier4	Tier4
	Slovenia	Tier4	Tier4
	Spain	Tier4	Tier4
	Sweden	Tier4	Tier4
Switzerland	Tier4	Tier4	
United Kingdom	Tier4	Tier4	
Middle East	Bahrain	Tier4	Tier4
	Egypt	N/A	Tier4
	Israel	Tier4	Tier4
	Oman	Tier4	Tier4
	Qatar	Tier4	Tier4
	Saudi Arabia	Tier4	Tier4
	United Arab Emirates	Tier4	Tier4

N/A = Unlimited plan is not available

## Partner Internet Access – Global Managed LEO / Global Managed LEO Plus - SLA Tiers -

Region	Countries	Global Managed LEO	Global Managed LEO Plus
Americas	Argentina	Tier4	Tier2
	Brazil	Tier4	Tier2
	Canada	Tier4	Tier2
	Chile	Tier4	Tier2
	Colombia	Tier4	Tier2
	Costa Rica	Tier4	Tier2
	Ecuador	Tier4	Tier2
	El Salvador	Tier4	Tier2
	Guatemala	Tier4	Tier2
	Mexico	Tier4	Tier2
	Panama	Tier4	Tier2
	Paraguay	Tier4	Tier2
	Peru	Tier4	Tier2
	United States	Tier4	Tier2
	Uruguay	Tier4	Tier2
US Virgin Islands	Tier4	Tier2	
Asia Pacific	Australia	Tier4	Tier2
	Guam	Tier4	Tier2
	Indonesia	Tier4	Tier2

Region	Countries	Global Managed LEO	Global Managed LEO Plus
	Japan	Tier4	Tier2
Asia Pacific	Malaysia	Tier4	Tier2
	Mongolia	Tier4	Tier2
	New Zealand	Tier4	Tier2
	Philippines	Tier4	Tier2
	Singapore	Tier4	Tier2
	Vanuatu	Tier4	Tier2
	Europe	Austria	Tier4
Belgium		Tier4	Tier2
Bulgaria		Tier4	Tier2
Croatia		Tier4	Tier2
Cyprus		Tier4	Tier2
Czech Republic		Tier4	Tier2
Denmark		Tier4	Tier2
Estonia		Tier4	Tier2
Finland		Tier4	Tier2
France		Tier4	Tier2
Germany		Tier4	Tier2
Greece		Tier4	Tier2

Region	Countries	Global Managed LEO	Global Managed LEO Plus
	Hungary	Tier4	Tier2
Europe	Iceland	Tier4	Tier2
	Ireland	Tier4	Tier2
	Italy	Tier4	Tier2
	Latvia	Tier4	Tier2
	Lithuania	Tier4	Tier2
	Luxembourg	Tier4	Tier2
	Malta	Tier4	Tier2
	Netherlands	Tier4	Tier2
	Norway	Tier4	Tier2
	Poland	Tier4	Tier2
	Portugal	Tier4	Tier2
	Romania	Tier4	Tier2
	Slovakia	Tier4	Tier2
	Slovenia	Tier4	Tier2
	Spain	Tier4	Tier2
	Sweden	Tier4	Tier2
	Switzerland	Tier4	Tier2
	United Kingdom	Tier4	Tier2

colt

Quote to Delivery High Level Processes

# Global Wireless Access - Quote to Delivery Process -

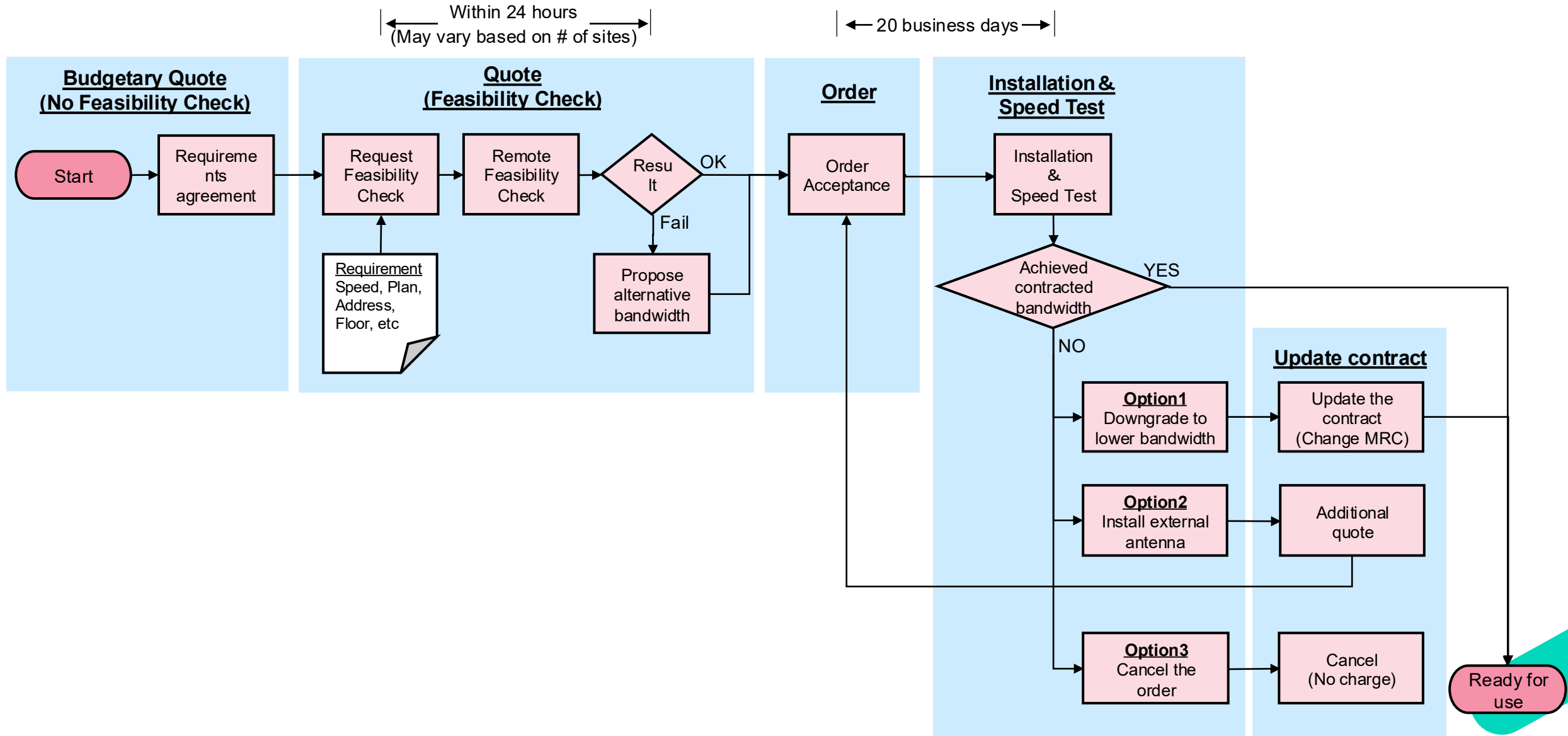

colt

Appendix

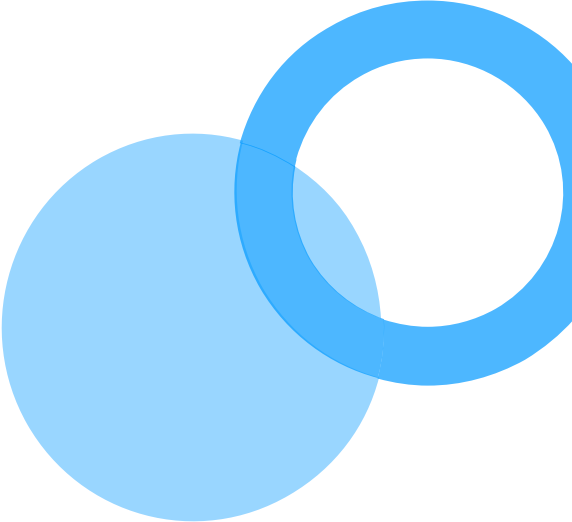
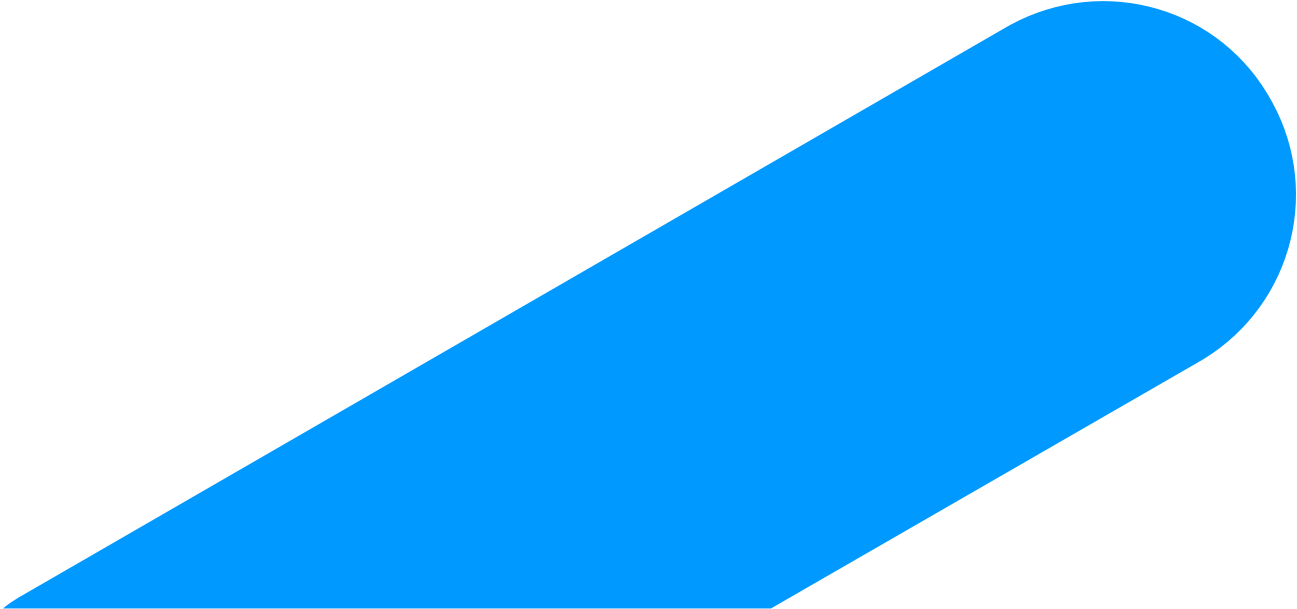
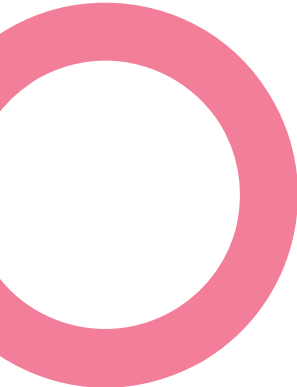

## Appendix: Mobile Router (Cradlepoint)



### Cradlepoint CBA850

Size	122 x 122 x 42 mm (4.8 x 4.8 x 1.7 in)
Weight	350 g (12.8 oz)
Power	AC100-240V
Consumption	Idle: 4.0 W Single modem: 6.0 W

### Cradlepoint E300

Size	135 x 270 x 44 mm (5.3 x 10.6 x 1.7 in)
Weight	820 g (1 lb 13 oz)
Power	AC100-240V
Consumption	24 W

### Cradlepoint IBR600C

Size	118 x 113.5 x 29.3 mm (4.6 x 4.5 x 1.2 in)
Weight	400 g (14 oz)
Power	AC100-240V
Consumption	Idle: 4 W Wi-Fi TX/RX: 9 W LTE TX/RX: 6.25 W

- Customer can specify the router model. We will select and determine the optimal router model to be installed at the customer's premises based on the location, bandwidth category, data plan, and optional features required.
- Routers other than those listed above may be installed.

## Appendix: StarLink Antenna / Wi-Fi Router

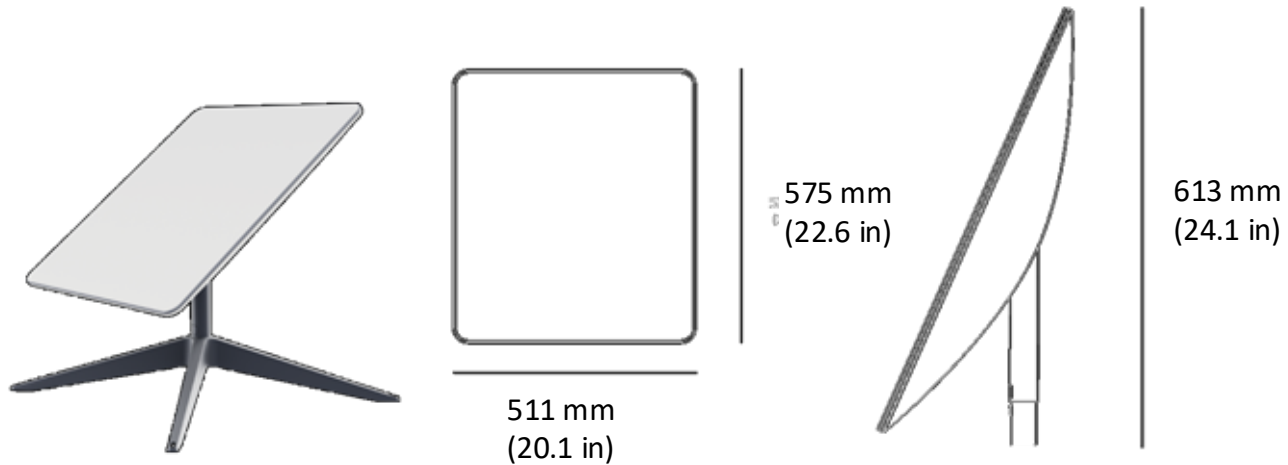

### STARLINK PERFORMANCE ANTENNA

Antenna	Electronic Phased Array
Orientation	Motorized Self Orienting
Environmental Rating	IP56
Snow Melt Capability	Up to 75mm / hour (3in / hour)
Operating Temperature	-30°C to 50°C (-22°F to 122°F)
Field of View	140°
Average Power Usage	110-150W

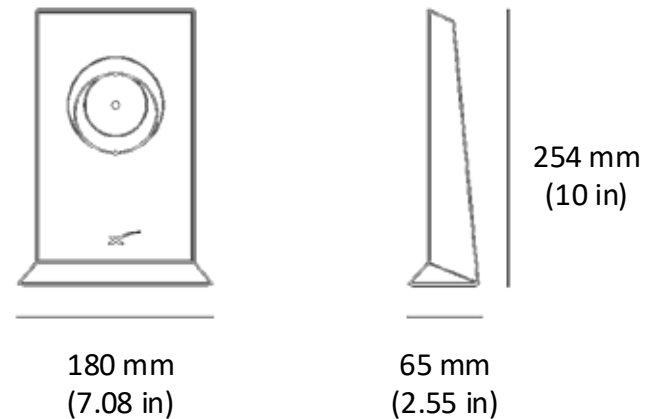

### STARLINK WIFI ROUTER

Wi-Fi Technology	IEEE 802.11a/b/g/n/ac standards
Generation	Wi-Fi 5
Radio	Dual Band - 3 x 3 MIMO
Security	WPA2
Environmental Rating	IP54, configured for indoor use
Coverage	Up to 185m <sup>2</sup> (2000sqft)
Operating Temperature	-30°C to 50°C (-22°F to 122°F)

- Thank you!

